



FLAMINGO

WE DESIGN DREAM INTO REALITY

We are professional interior designer and execution company

Home / Commercial Interiors

On-time Delivery | Reliable Results | Hassle Free Execution



FLAMINGO INTERIOR

WE DESIGN DREAM INTO REALITY

SYSTEM CABINET STRUCTURE



AGENDA

01

BOARD

02

HARDWARE

03

STRUCTURE & FEATURES



FLAMINGO INTERIOR

WE DESIGN DREAM INTO REALITY

BOARD



E1 STANDARD SOLID WOOD PARTICLE BOARD

- ❑ Is an engineered wood product manufactured from chips, sawmill shavings, or even sawdust, and a synthetic resin or other suitable binder, which is pressed and extruded.
- ❑ It uses oriented strand board techniques, which can make the final product moisture-resistant, stable & strong, anti-bending, and eco-friendly.





E1 STANDARD MDF (MEDIUM DENSITY FIBERBOARD)

- ❑ Is an engineered wood product made by breaking down hardwood or softwood residuals into wood fibers, often in a defibrator, combining it with wax and a resin binder, and forming panels by applying high temperature and pressure.
- ❑ MDF is generally denser than plywood. It is made up of separated fiber, but can be used as a building material similar in application to plywood. It is stronger and much denser than particle board.





SYSTEM CABINET BASE BOARD

Thickness 9mm

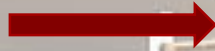

Sliding door panel, back panel

Thickness 18mm



Shelf, side panel, flat door panel

Thickness 22mm



Worktop of desk, base unit

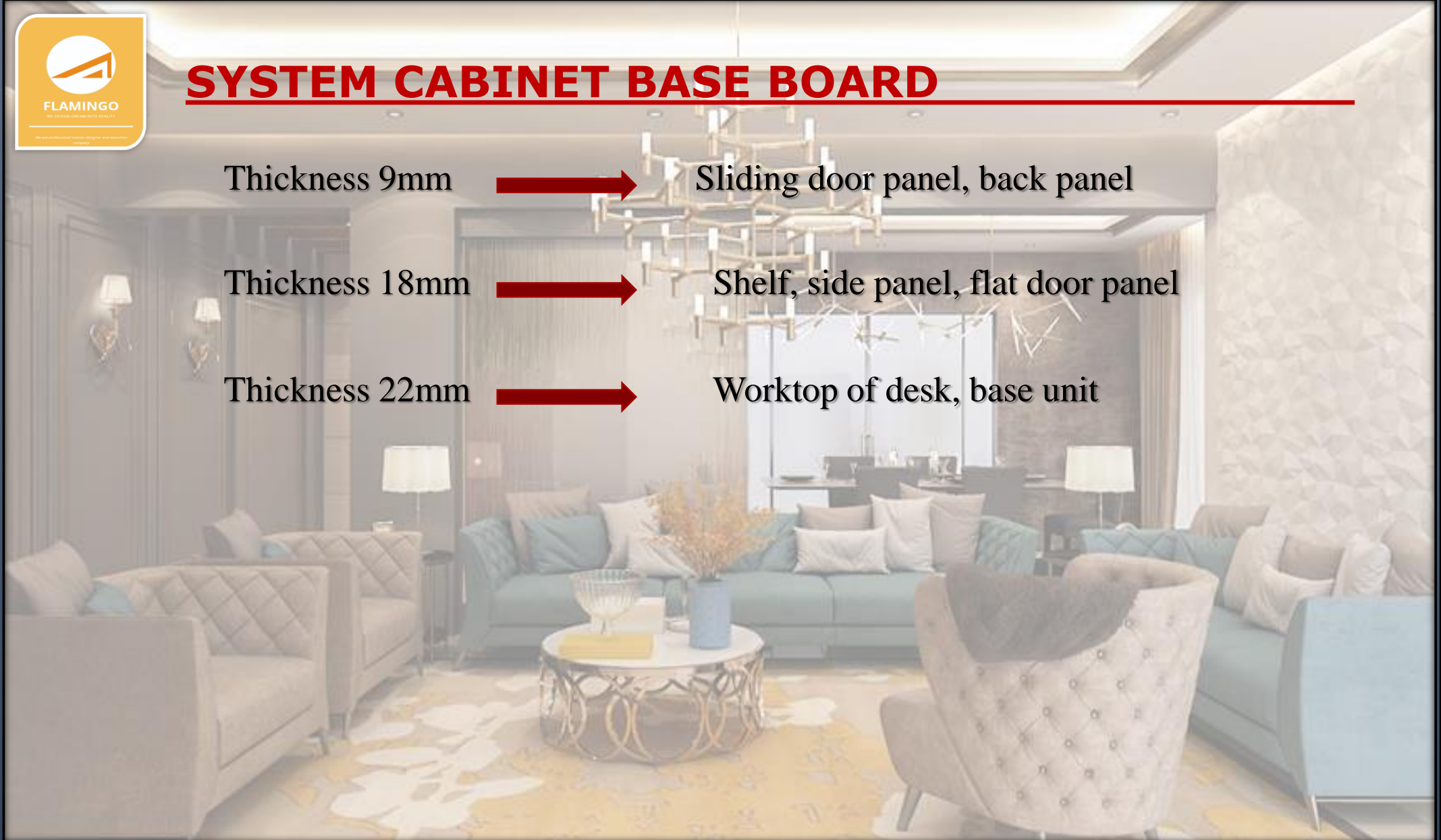



SYSTEM CABINET DOOR SHAPE (4 SHAPES)

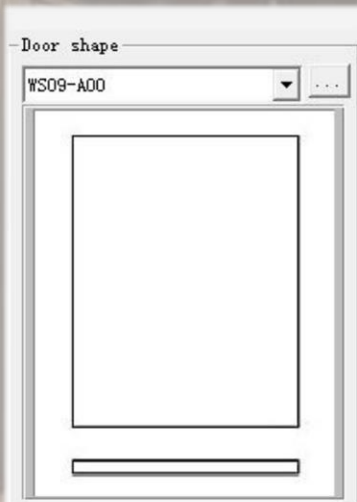

Flat door

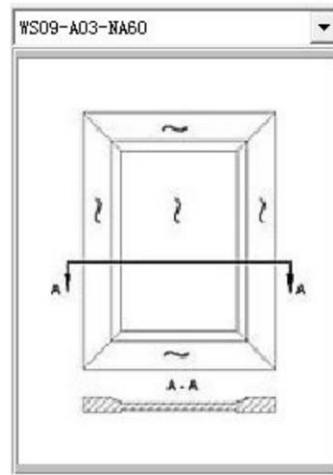

Classical style door

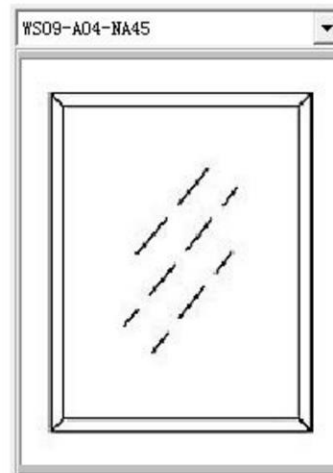

Alu-frame door

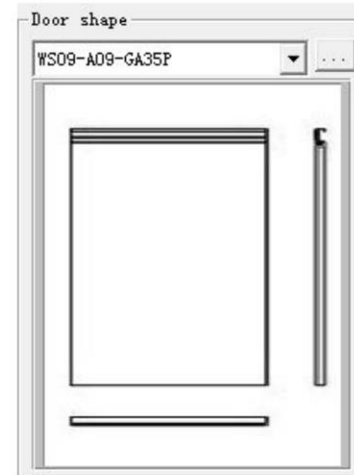

Door with built-in handle



SYSTEM CABINET DOOR MATERIAL – FLAT DOOR

Select Door Style

Style series: System Cabinet Door Door class: WS09-A00-Flat Door

Door shape: WS09-A00

Argent Acacia	Bright Green	Deep Pink	Iris Walnut
Irish Cream	Mahogany	Maroon	Neo Highland Pine
Nova Teak	Portland Maple	Red	Sapelle

Parameter	Value
Flat Door	

Display: All Usable Downloaded Searched Find what: Find OK Cancel



SYSTEM CABINET DOOR MATERIAL-DOOR WITH BUILT IN HANDLE

Select Door Style

Style series: System Cabinet Door Door class: WS09-A09-Built-in Handle

Door shape: WS09-A09-GA35P

Argent Acacia	Bright Green	Deep Pink	Iris Walnut
Irish Cream	Mahogany	Maroon	Neo Highland Pine
Nova Teak	Portland Maple	Red	Sapelle

Parameter Value

Aluminum built-in handle G type-steel silver, on top.

Display: All Usable Downloaded Searched Find what: Find OK Cancel



SYSTEM CABINET DOOR MATERIAL - CLASSICAL

Select Door Style

Style series: System Cabinet Door Door class: WS09-A03-Neoclassical Style

Black Knight England White Oak Ivory White

Door shape: WS09-A03-NA45

Parameter	Value
Classic Frame Door, Inner can be changed.	

Display: All Usable Downloaded Searched Find what: Find OK Cancel



SYSTEM CABINET DOOR MATERIAL- ALU-FRAME DOOR

Select Door Style

Style series: Door class:

Pure Black Silver White

Door shape:

Parameter	Value
Aluminum Frame Glass Door	

Display: All Usable Downloaded Searched Find what: Find

OK Cancel



FLAMINGO INTERIOR
WE DESIGN DREAM INTO REALITY

HARDWARE



HINGE FOR SYSTEM CABINET & WARDROBE (KITCHEN CABINET NOT INCLUDED)

□ Standard configuration, Hettich hinge



□ Full overlay



□ Half overlay



□ Inset overlay



□ Full overlay (Quick-assemble)

SYSTEM CABINET CONNECTOR

- Standard configuration, Hettich hinge



□ 3 in 1 connector



□ Shelf connector



□ Connecting screw



□ Drawer runner, fully extension



FLAMINGO INTERIOR

WE DESIGN DREAM INTO REALITY

STRUCTURE AND FEATURES



CABINET STRUCTURE

❑ System cabinet is made of 3 components: worktop, unit body and plinth or platform.

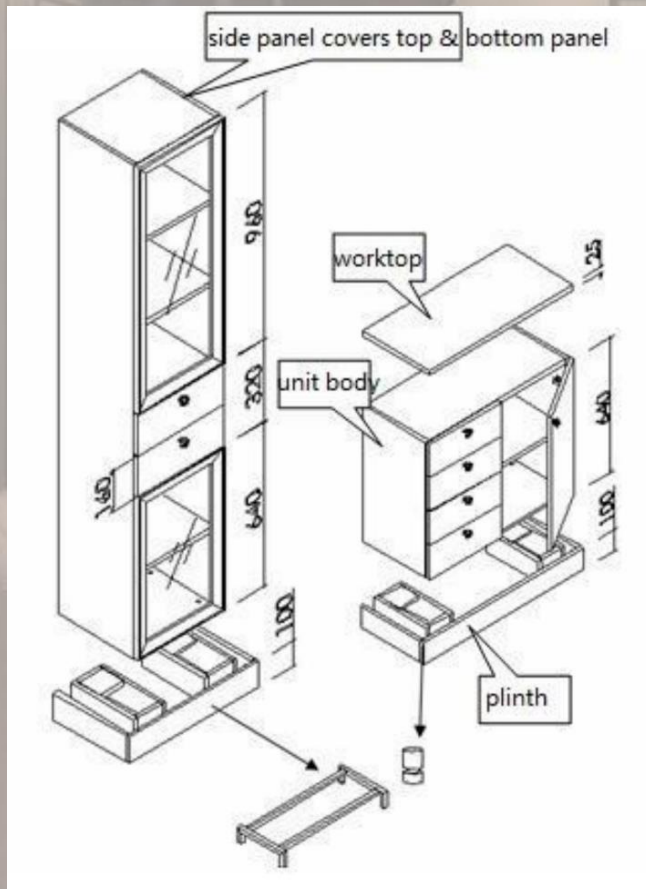

- ❑ The height of single unit is 320mm. Height increment is 320mm.
- ❑ Standard wood platform (100mm)
- ❑ Swing door can be replaced by aluminium framed glass door and new door style.
- ❑ When the net height of cabinet is over 1600mm, no worktop in principle.



INSTALLATION STEPS OF SYSTEM CABINET

❑ System cabinet is made of 3 components: worktop, unit body and plinth or platform.

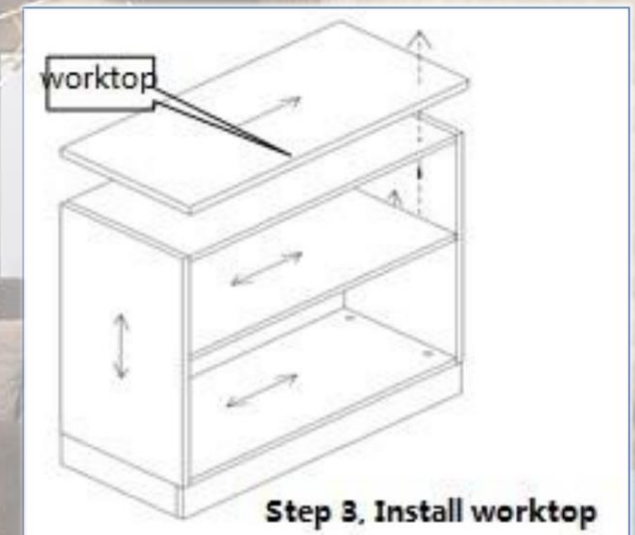
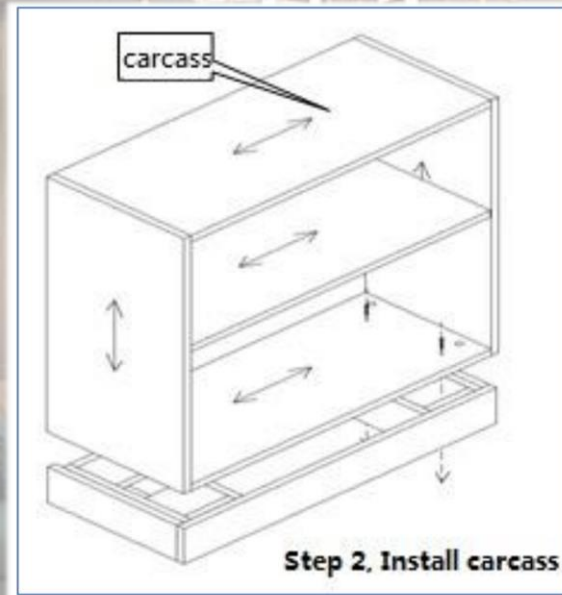
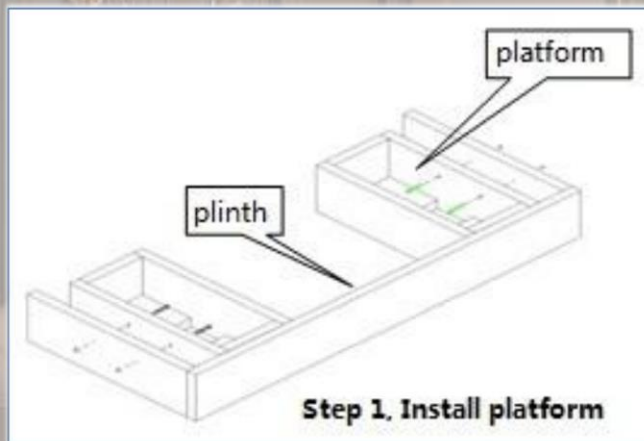



INSTALLATION STEPS OF SYSTEM CABINET

❑ Back panel

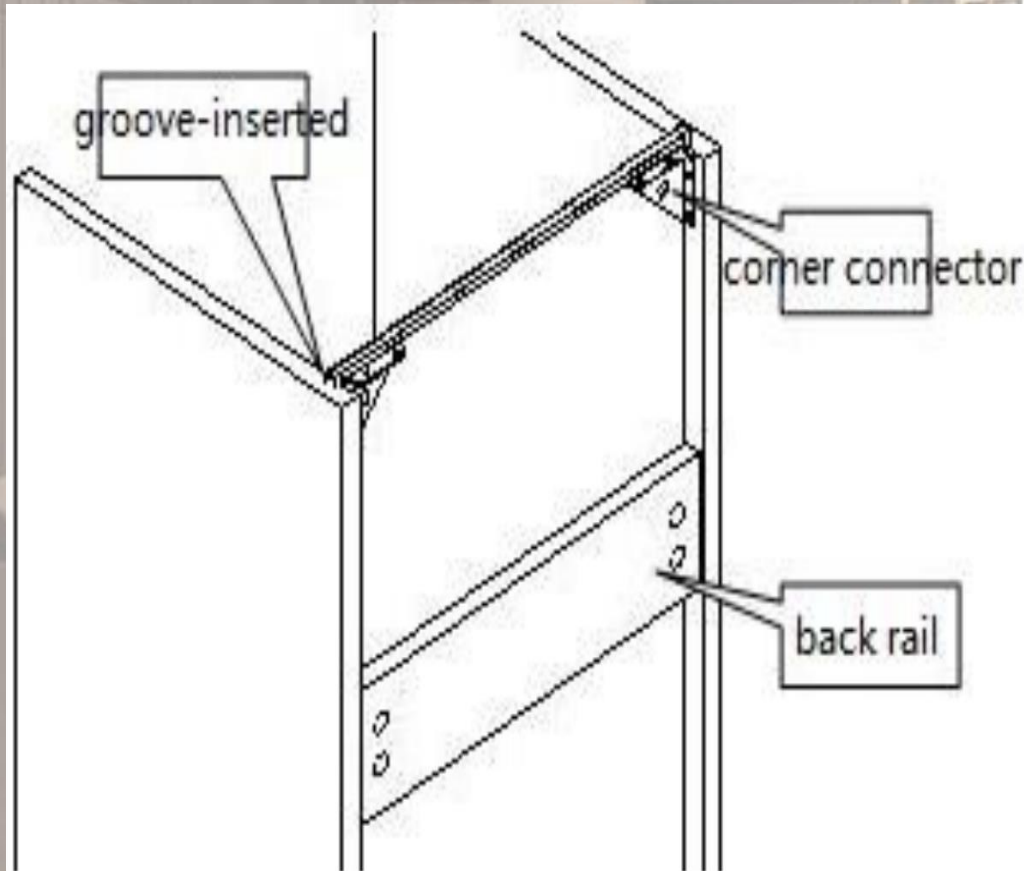

- ❑ All drawer & door panel is full-cover type, no built-in type.**
- ❑ Back panel of system cabinet applies groove-inserted structure, connector in four corners to fix the cabinet. A back rail will be added for tall unit.**
- ❑ Back panel thickness is 9mm, groove is 20mm away from the back. Including the groove, depth is 30mm. (Image attached is a tall unit. No back rail for base unit).**



INSTALLATION STEPS OF SYSTEM CABINET

❑ Drawer

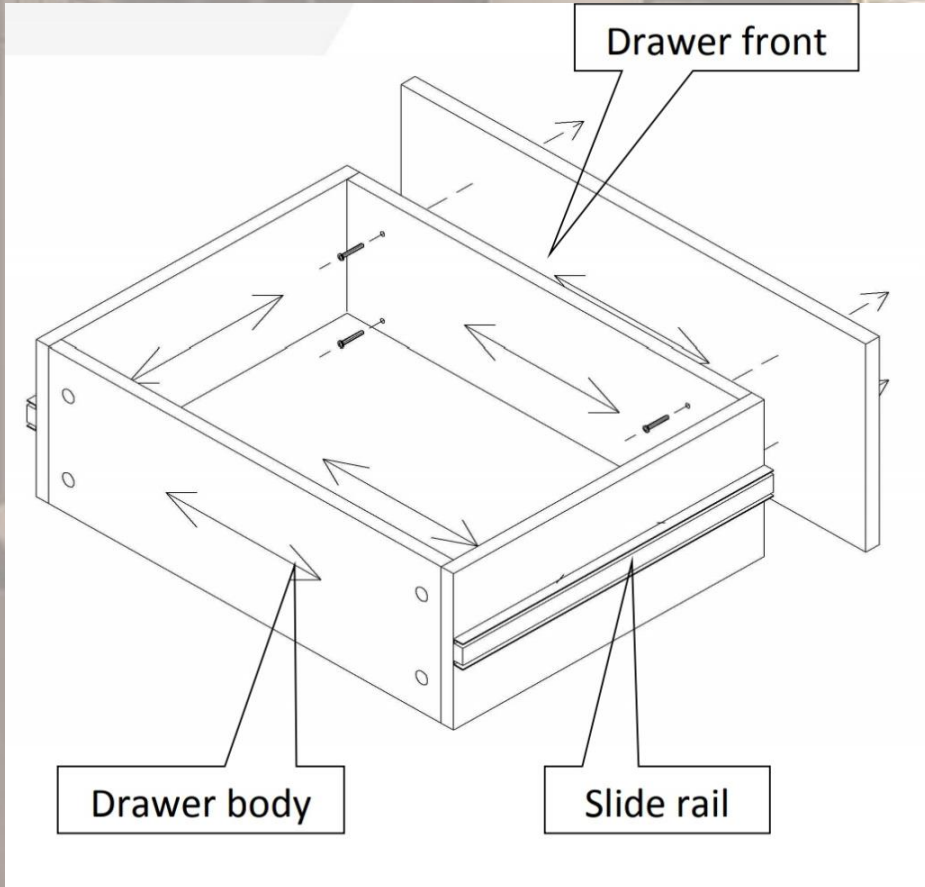

- ❑ There are 3 size of drawer height, 160/240/320mm. As for drawer structure, we use drawer front board to separate drawer body and front board.
- ❑ Thickness of front board, drawer body is 18mm, bottom panel is 9mm.
- ❑ The standard slide rail length is 250/300/350/400/450.



STANDARD SIZE OF SYSTEM CABINET

❑ Width:

1-column unit: 400,500,600

2-column unit: 800,1000,1200

3-column unit: 1200,1500,1800

4-column unit: 1800,2000,2400 (base unit)

❑ Height: 160,240,320,480,640,720,800,960,1280,1600,1920,2080,2240

❑ Depth: 298,350,398,560





FREQUENTLY-USED CABINET DIMENSION

Base unit, TV-unit:

- H 160/240/320 (Worktop & platform not included)
- D 398 (door panel not included)

Wall unit, TV unit/ Bookcase:

- D 220/298 (door panel not included)

Bookcase:

- D 298/350 (door panel not included)
- One column unit width should be less than 500
- H 640/960/1280/1600/1920 (Worktop & platform not included)

Writing desk:

- H 765; D 600

Nightstand:

- H 240/320 (Worktop & platform not included)
- W 400-600
- D 350/398 (door panel not included)

Swing door wardrobe:

- D 560 (door panel not included)
- H 2180 (Worktop & platform not included)



FEEL FREE, YOU ARE WITH FLAMINGO



**FREE ON-SITE
MEASUREMENT**



**FREE
DESIGN**



**FREE
3D RENDER**



**FREE
DELIVERY**



**FREE
INSTALLATION**



THANK YOU



<https://www.linkedin.com/company/flamingo-interior/>



https://www.instagram.com/interior_flamingo

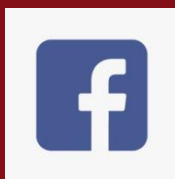

<https://www.facebook.com/Flamingointerior>



<https://www.flamingointerior.com/>



https://twitter.com/_flamingodesign



Thank You!



Office - Spacedge , B block , Third floor, Sohna road, Gurgaon

Factory - 23A, Ground floor, Pitampura Village, Near Aggarsen bhawan, Delhi, India.



www.flamingointerior.com

info@flamingointerior.com



Tel: +91 99990 98488